

## Features

- 800 - 900MHz
- 21 dB Gain at 824MHz
- +25.5 dBm Output IP3
- 0.75 dB Noise Figure
- No matching circuit needed
- Low power consumption (3V/52mA)
- Surface mount type

## Applications

- LNA for PCS
- Repeater
- Base Station
- Mobile Infrastructure

## Functional Diagram

Function	Pin No.
RF IN	2
RF OUT	5
Vcc	6
Ground	1,3,4

## Description

The PLF08A is a high performance GaAs p-HEMT LNA (Low Noise Amplifier). The amplifier features high linear performance, low noise figure, low power consumption and high reliability. The PLF08A operates from a single voltage supply and no matching circuit needed. The device is a superior performance p-HEMT amplifier that offers high dynamic range in a low cost miniature surface mount type with metal cover. These PLF series provide the most suitable solutions for LNA in communication systems.

## Specifications

Symbol	Parameters	Units	Freq.	Min.	Typ.	Max.
S21	Gain	dB	824 MHz 894 MHz		21.0 20.0	
S11	Input Return Loss	dB	824 MHz 894 MHz		-18 -18	
S22	Output Return Loss	dB	824 MHz 894 MHz		-8 -8	
P1dB	Output Power @1dB compression	dBm	824 MHz 894 MHz		13 13	
OIP3	Output Third Order intercept	dBm	824 MHz 894 MHz		25.5 25.5	
NF	Noise Figure	dB	824 MHz 894 MHz		0.75 0.75	
V / I	Device Voltage / Current	V/mA			3.0/52	

## Typical RF Performance

### Gain vs. Frequency

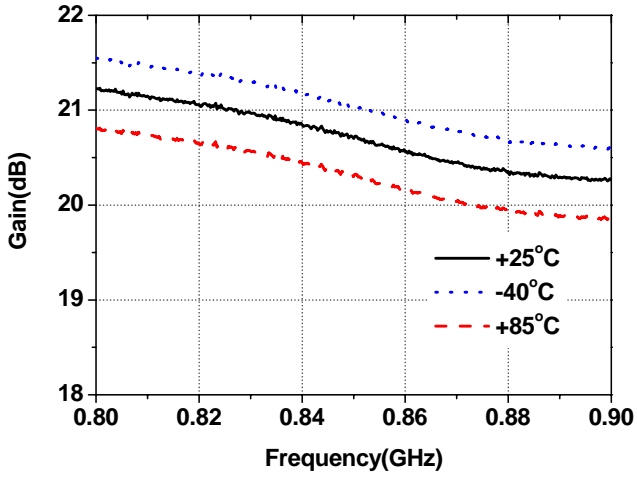

### NF vs. Frequency

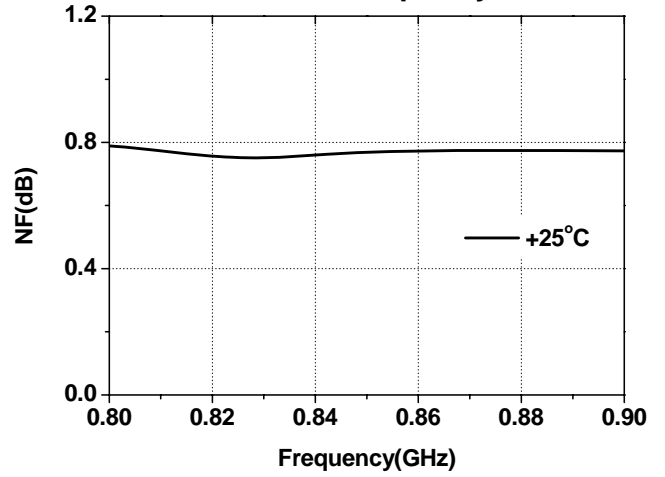

### Input Return Loss

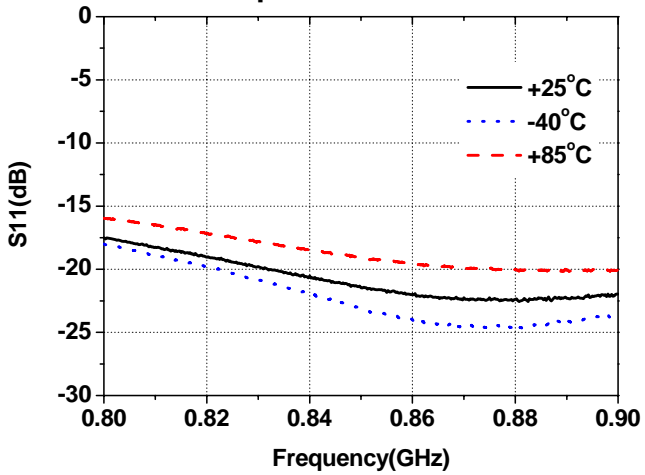

### Output Return Loss

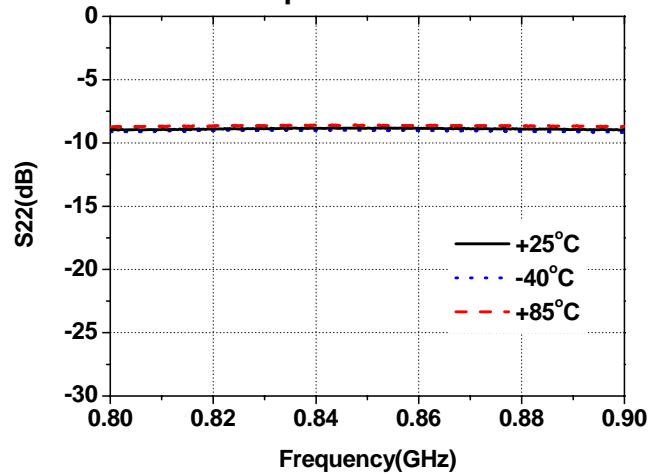

### Output IP3 vs. Frequency

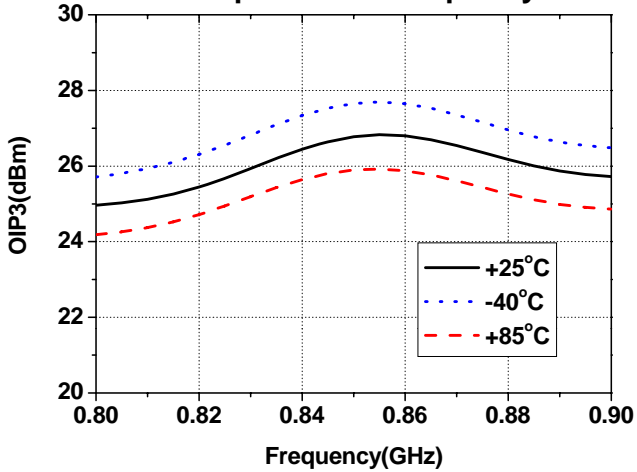

### P1dB vs. Frequency

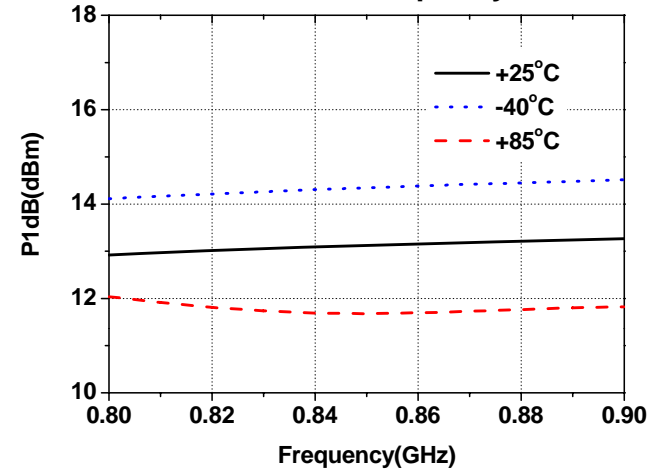

## Absolute Maximum Ratings

Parameter	Rating	Unit
Supply Voltage	+6	V
Supply Current	66	mA
RF Power Input	10	dBm
Storage Temperature	-55 to +125	°C
Ambient Operating Temperature	-40 to +85	°C

Operation of this device above any of these parameters may cause permanent damage.

### Outline Drawing

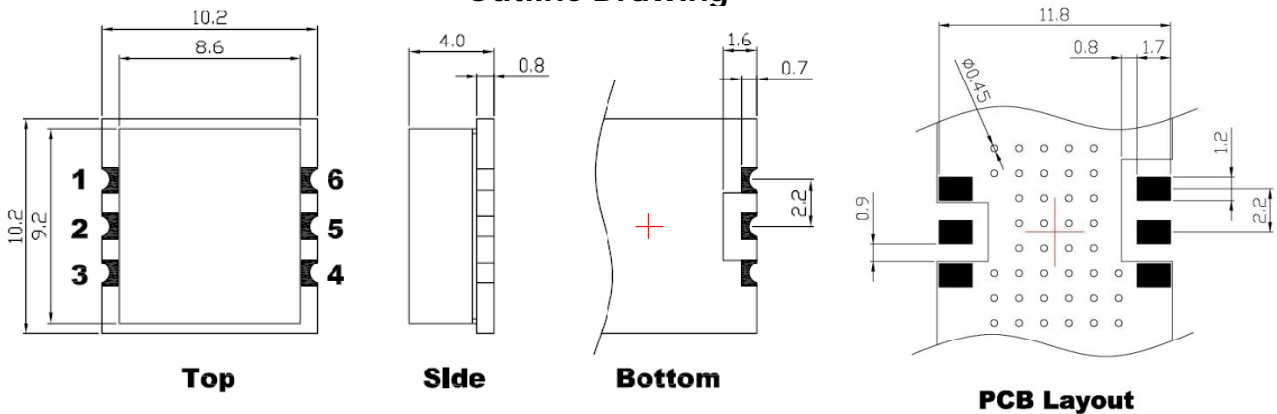

### Soldering Time Profile

1. Maximum temperature: +260°C or below.
2. Time at maximum temperature: 10s or less
3. Time of temperature higher than +220°C : 60s or less
4. Preheating time at +120°C to +180°C: 120±30s
5. Maximum number of reflow process : 3times
6. Maximum chlorine content of rosin flux (percentage mass) : 0.2% or less

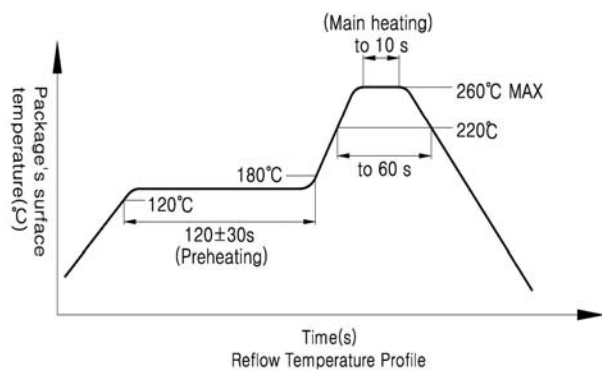

### Evaluation Board Layout (2.3x2.3)

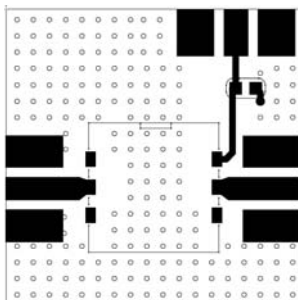

### Mounting Instructions

1. Use a large ground pad area with many plated through-holes as shown.
2. We recommend 1 oz copper minimum.
3. Measurement for our datasheet was made on 0.8mm thick FR-4 Board.
4. Add as much copper as possible to inner and outer layers near the part to ensure optimal thermal performance.
5. RF trace width depends on the board material and construction.